

FDK



MULTI-2000

**144MHz
FM/SSB/CW
10 WATTS
200 CHANNELS**

INSTRUCTION MANUAL

FUKUYAMA

ELECTRONICS CO., LTD.

MULTI-2000

SHIMADZU
CORPORATION
ATTORNEY
GENERAL

CONTENTS

FEATURES OF MULTI-2000	1
SPECIFICATIONS	2
ACCESSORIES	2
NAMES AND OPERATION OF THE DIFFERENT PARTS ..	3
SCHEMATIC DIAGRAM	5
HOW TO CONNECT	7
NOTES FOR OPERATION	8
HOW TO OPERATE	9
CIRCUIT DESCRIPTION	11
INTERNAL VIEW	13
BLOCK DIAGRAM	14

FEATURES OF MULTI-2000

The MULTI-2000 is a super-high-class transceiver, made by Fukuyama, specialized maker of communication equipment, using the newest electronics technology, effecting simultaneous multimode and multi channelization in the 144 MHz band. We are convinced that this professional 2 m almighty transceiver will give complete satisfaction for the beginner as well as for the veteran.

■ **All solid state, all mode (SSB, FM, CW) 2 m transceiver**

This is a multimode transceiver for the 144 MHz band with all solid state construction under abundant use of the newest semiconductors like IC, FET, etc. With one unit transmission and reception of FM, SSB, and CW is possible.

■ **200 CH at 10 kHz steps by phase lock synthesizer**

Continuous cover from 144 to 146 MHz is possible by additional ± 7 KHz VXO.

By means of the digital phase lock synthesizer, using the newly developed IC for PLL, transmission and reception on 200 CH in 10 KHz steps from 144 to 146 MHz is possible with excellent stability. By use of the ± 7 KHz VXO, continuous cover from 144.00 to 146.00 MHz is possible in the same way as with the conventional VFO.

■ **FM narrow band (5 kHz) change-over switch**

In response to the multichannelization of the FM band, a narrow band change-over switch is installed, so that transmission and reception with 20 KHz separation are possible. Transmission with a separation of 20 KHz from any other channel prevents interference with the other station.

■ **Fixed-channel transmission and reception possible (4 channels)**

4 fixed channels can be set for FM. Crystal for fixed channel can be installed as options (one crystal method). Please use this for the club channel of your station or for a "secret channel".

■ **Use as fixed station or mobile station (power supply AC V, DC 13.5 V)**

The power supply is for AC and DC, so that it can be used as a fixed station or as a mobile station. (Holder for car installation optional).

■ **Powerful noise blanker for SSB built-in**

The newly developed noise blanker is built-in. As ignition noise in road areas, pulse noise, and interference are completely eliminated, clear communication can be enjoyed.

■ **Use of exclusive center meter for FM**

As a center meter independent from the S&RF meter is installed, exact adjustment to the center frequency of the opposite station is possible with the RIT knob. By RIT operation the reception frequency can be changed more than 5 kHz without change of the transmission frequency.

■ **Sensitivity change-over (Local - DX) installed**

A sensitivity change-over, effective against interference and cross modulation, is installed. Please use it for switching according to the wave conditions and the application purpose.

■ **Patented AFB squelch built-in**

The well recognized "Fukuyama squelch" is built-in. This smooth, continuous squelch is very effective for stand-by reception, schedule QSO, etc.

■ **2 level signal output change-over for FM (10W-1W)**

As the signal output for FM can be switched to 10 W or to 1 W, suitable switching can be done for local stations or for DX stations.

■ **Test button for SSB frequency adjustment installed**

A test button for the various adjustments for SSB operation is installed. This is convenient for adjustment of the antenna etc., as an 800 Hz modulation SSB wave, independent from the mike input, is put out, when this switch is switched on.

■ **Conventional repeater station operation is possible.**

When the fixed channel knob is switched to Duplex, repeater station operation by the synthesizer is possible. When the synthesizer knob is set to the frequency of the repeater station, a transmission frequency at a fixed difference in frequency is sent out.

SPECIFICATIONS

Mode	FM (F ₃)	SSB (A _{3J}) CW (A ₁)
Transmission and reception frequency	144 to 146 MHz (from 144.00 MHz 200 CH at 10 KHz separation built-in (direct frequency method) and continuous cover from 144 to 146 MHz by more than ±7KHz variable VXO)	
RF power output	10 W (high), approx. 1W (low)	10 W (PEP) USB
Modulation system	Variable reactance frequency mod.	Balanced modulation
Max. frequency dev.	Wide 12 KHz, narrow 5 KHz	
Multiplication factor	(128.1 + 16.9) × 1 MHz	
Carrier suppression ratio	More than 45 dB	
Side band suppression ratio	More than 50 dB	
Spurious radiation	Less than -60 dB	
Antenna impedance	50 Ω	
Microphone	500 Ω dynamic microphone (500 to 600 Ω possible)	
Transmission frequency characteristic	300 to 3000 Hz (-6 dB)	
Reception system	Double superheterodine	Single superheterodine
Intermediate frequency	1st IF 16.9 MHz 2nd IF 455 KHz	1st IF 16.9 MHz
Reception sensitivity	More than S/N 30 dB at 1 μV input (50 mW)	More than S/N 10 dB at at 0.3 μV input (50 mW)
Image ratio	More than 60 dB	
Selectivity	More than 15 KHz (at -6 dB) Less than 20 KHz (at -60 dB)	More than 2.4 KHz (at -6 dB) Less than 4.4 KHz (at -60 dB)
Audio output	More than 2 W (8 Ω, 10% distortion)	
Power consumption	DC 13.8 V max. 3.2 A	
Supply voltage	AC V, DC 13.5 V	
Semiconductors	16 IC's, 9 FET's, 58 transistors, 59 diodes, 1 SCR and 2 thermistor	
Dimensions / weight	85 (H) × 340 (W) × 295 (D) / approx. 7 kg.	

ACCESSORIES

1) Dynamic microphone, 1 pc.

This is a dynamic microphone with a press-to-talk switch and with coiled cord and 4 P plug. This hand microphone further has a mike hanger. The mike impedance is 500 Ω.

2) DC cord, 1 pc.

This power supply cord is used for DC power supply operation (DC 13.8 V) and is a 2 m long red and black parallel cord with a relay fuse. Red is (+), black is (-), and the fuse has 5 A.

3) AC cord, 1 pc.

This power supply cord is used for AC power supply operation.

4) Spare fuses, 5 A and 1 A, 1 pc. each

5) External plugs, 2 pcs.

For external speaker and key terminals.

6) Accessory plug (9 P), 1 pc.

7) Instruction manual, 1 pc.

NAMES AND OPERATION OF THE DIFFERENT PARTS

○ **Test switch**

This switch is used for transmission check, antenna adjustment, etc. When the switch is pressed, the 800 Hz tone circuit operates, and for FM it becomes a tone of 800 Hz, while for SSB the standard transmission frequency is sent out.

○ **Noise blanker switch**

This switch is switched on in cases with much pulse noise at reception, especially ignition noise from cars etc., so that the noise is eliminated and clear communication becomes possible. It is especially effective for SSB.

○ **Center meter (inoperative for SSB)**

This reads the aberration of the FM reception frequency. By centering of the pointer with the RIT or the VXO knob, reception without F aberration is possible.

○ **S meter**

This indicates the input signal strength (S) for reception and the output signal strength (PO) for transmission. At the output signal strength of 10 W it indicates about [8].

○ **Synthesizer frequency selector switch**

These are selector switches for units of MHz, 100 KHz, and 10 KHz from the left. By combination of these 3 switches QSY with 10 KHz separation is possible for any channel. The switches for 100 KHz and 10 KHz indicate 0 and 1 twice each. The MHz units are indicated from 144 to 147, but for 146 and 147 MHz only reception is possible.

○ **Mike jack (MIC)**

This jack serves for connection of the accessory microphone. Transmission is done by pressing of the press-to-talk switch. The terminal connection is shown in the following drawing.

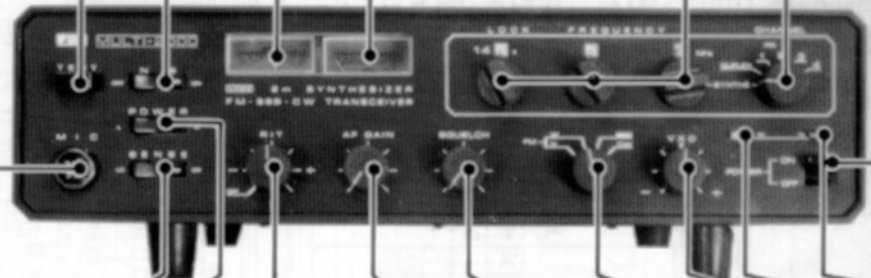
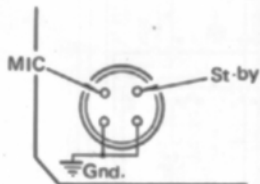

○ **RF gain knob**

This knob controls the RF gain. Turn the knob to the left, the RF gain is lowered for FM, RF and IF gain are lowered by the AGC for SSB, and the sensitivity drops 30 to 40 dB. By use for local QSO, interference and cross modulation can be prevented, and for SSB the distortion of the reception sound can be softened.

○ **Output power change-over switch (POWER)**

With this switch the output signal power can be switched in 2 levels. At high output (HI) it is 10 W, and at low output (LOW) it is approx. 1 W.

○ **RIT knob (Receiver Incremental Tuning)**

Fine tuning of the receiver frequency is done with the RIT knob. When the transmission frequency of the opposite station has an aberration, the receiver frequency can be changed independently. For FM it is convenient to watch the center meter directly above while correcting. The variable range exceeds ± 5 KHz. The RIT is switched OFF by turning completely to the left.

○ **Volume knob**

The volume is increased by turning the volume knob clockwise.

○ **Squelch knob (only for FM)**

The squelch is switched ON by turning clockwise. The squelch uses the patented AFB squelch of our company.

er frequency
vitch
ctor switches
Hz, 100 KHz,
rom the left.
n of these 3
with 10 KHz
ossible for any
switches for
10 KHz indi-
twice each,
are indicated
147, but for
MHz only re-
ible.

○ **Fixed-channel selector switch**
This is set to SYNTH for changing of the frequency by the synthesizer knob. For repeater station operation it is set to DUPLEX, and by use of the synthesizer with FM, all repeater station operations are possible. 4 fixed channels can be used for FM, and they are selected by switching of this switch. Use them for private channels etc. (Fixed-channel crystals are optional.)

○ **External speaker jack**
When an external speaker is used, it is connected to the equipment plug and this inserted into this jack.

○ **Name plate**
Here the unit number is stamped in.

○ **Power supply connector**
This is the power supply connector for AC and DC use. The equipment includes AC and DC power supply cord, and care is to be taken not to confuse them. (The DC cord is a parallel red and black cord, red is + and black is -.)
DC 13.8V
AC V

○ **Accessory terminal**
This is a 9 P socket for accessory connection. The connection of the terminals is shown in the drawing.

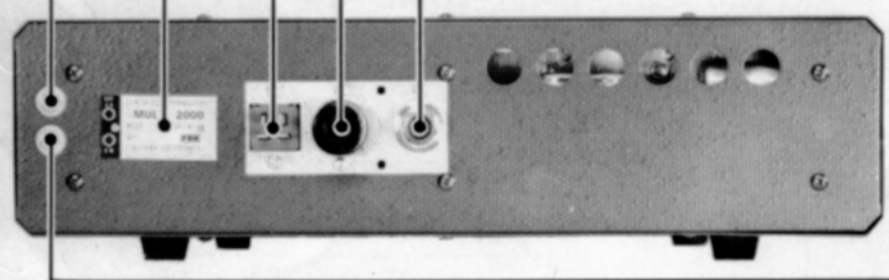
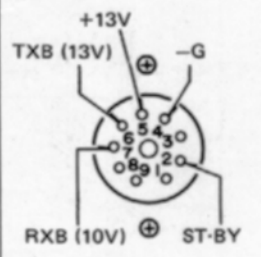

○ **Antenna connector**
Please use an M-type contact plug for the connection of the antenna at the connector seat. The impedance is 50 Ω.

○ **Key jack**
For CW transmission the equipment plug is connected to the key and inserted into this jack. Please use the stand-by circuit of the accessory terminal when using this unit exclusively for CW. When the stand-by terminal is made to earth, transmission takes place.

nob
FM)
switched ON
clockwise. The
the patented
of our com-

○ **Mode selector**
FM-N (narrow), FM-W (wide), SSB (USB), and CW mode can be selected. The maximum transmission frequency deviation is 5 KHz at FM narrow and 12 KHz at FM wide. SSB is the upper side band, and the jack for the CW key is on the rear panel.

○ **VXO knob (Variable X'tal Oscillator)**
This knob is used for the fine adjustment of reception and transmission frequency. When the RIT is OFF, transmission and reception frequency can be changed, and when it is on, only the transmission frequency can be changed. By turning of the

○ **Reception signal lamp**
This lamp lights up green during reception (RX).

VXO knob to the left and right from the center, ±7KHz change is possible. Accordingly the 10 KHz interval of the synthesizer can be covered continuously by VXO.

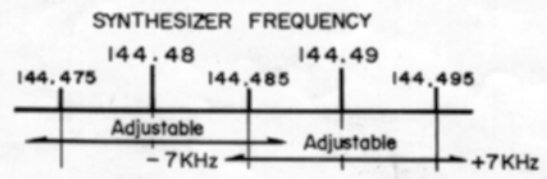

○ **Transmission signal lamp**
This lamp lights up orange during transmission (TX).

○ **Power switch**
When this switch is switched to the upper side, the power supply is connected and the set operates. When it is switched downwards, the power supply is cut off.

SCHEMATIC DIAGRAM

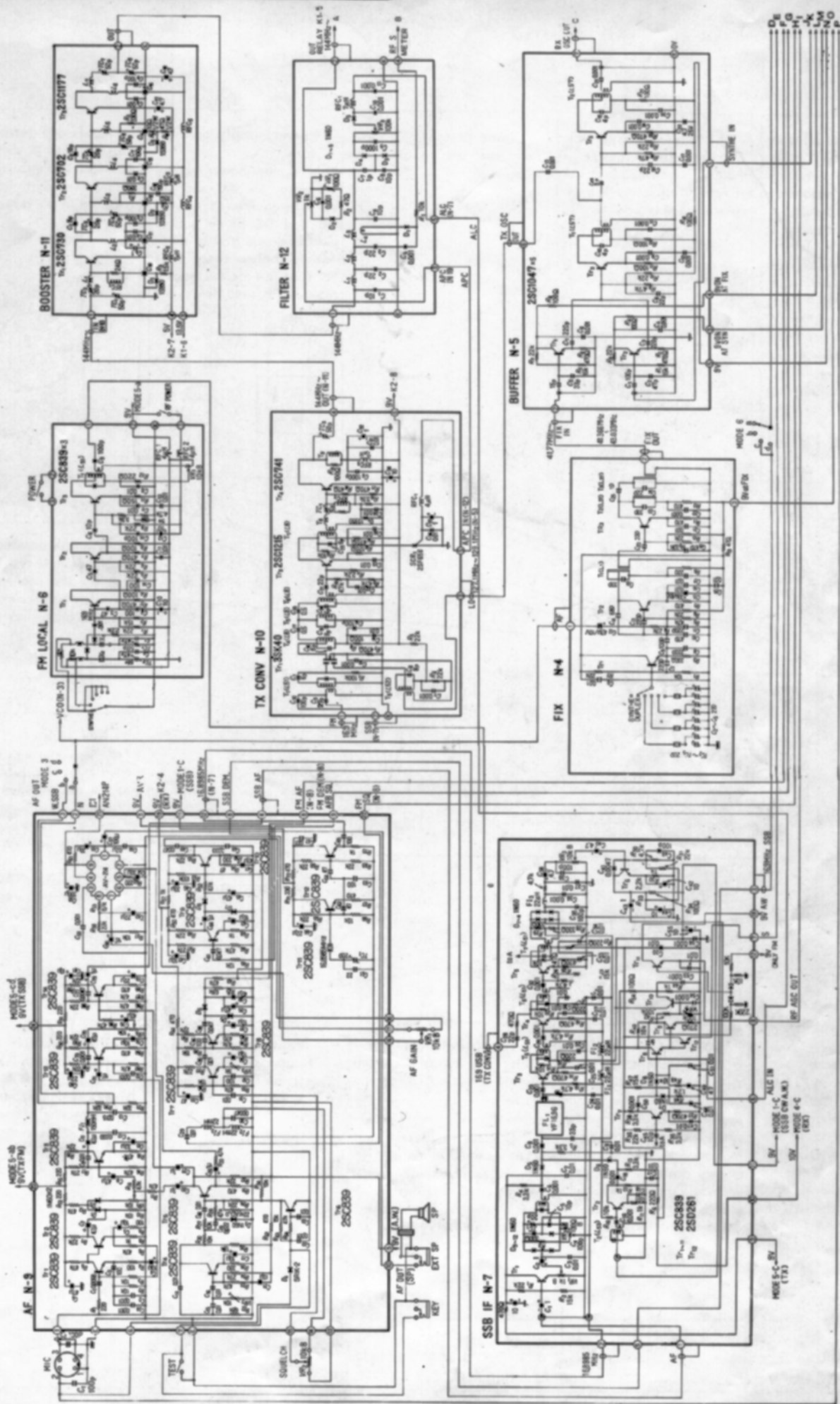

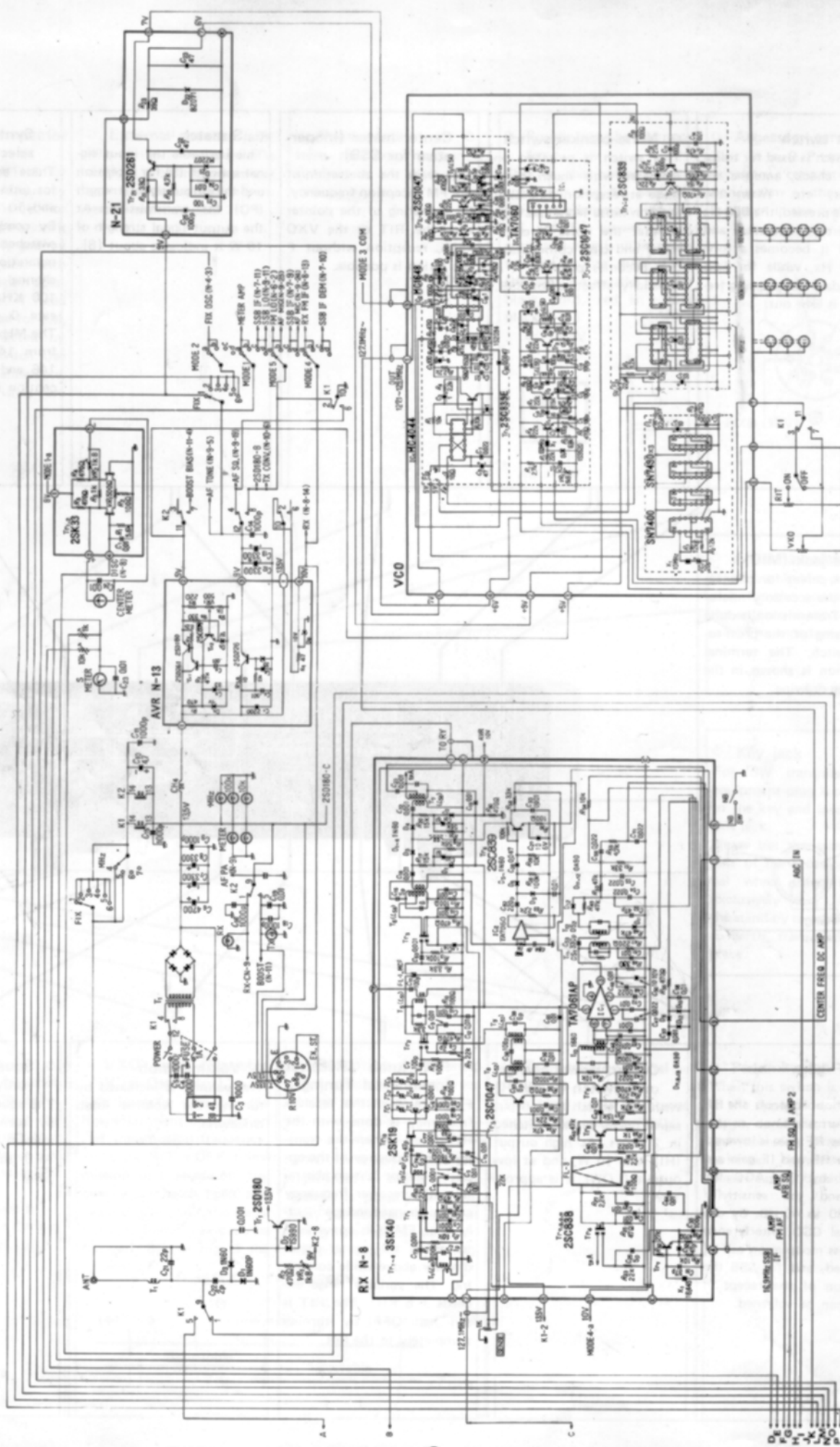

D_e
F_G
H₁
J_K
L_O
P₁₀

HOW TO CONNECT

1. Power supply

For use as a fixed station connect with the equipment AC cord to an AC V receptacle. This unit works normally in the range of AC $V \pm 10 V$, but when the voltage falls below this, the specified output is no longer obtained. In this case increase the voltage to AC V by transformer or similar for use.

For use in a car connect with the equipment DC cord (red and black). The red lead has to be connected to the + pole of the battery and the black lead has to be connected to the - pole of the battery.

2. Microphone

The equipment mike is inserted into the MIC connector and locked. When another mike is to be used, it should have an impedance of 500 to 600 Ω . In this case it is to be checked that the connection of the connector plug corresponds to the drawing shown page 3 "MIC jack".

3. Antenna

As the antenna is the entry and exit of the radio waves, it is a very important point for DX communication. When a poor antenna is used, the capacity can not be developed to a full 100%, no matter how superior the transceiver is. It is recommended to use a good antenna and to install it as high as possible.

As this unit has an output impedance of 50 Ω , it is to be connected to a 50 Ω antenna by a 50 Ω coaxial cable. (RG-5/U etc.) The drawing shows an example for antenna installation.

4. External speaker (headphone)

An 8 Ω external speaker or headphone is to be used. The equipment 3.5 ϕ plug is connected as shown in the drawing and is inserted into the EXT.SP jack on the rear panel.

5. Key

For use of a key, the equipment 3.5 ϕ plug is connected as shown above under "External speaker" and it is inserted into the KEY jack of the back panel.

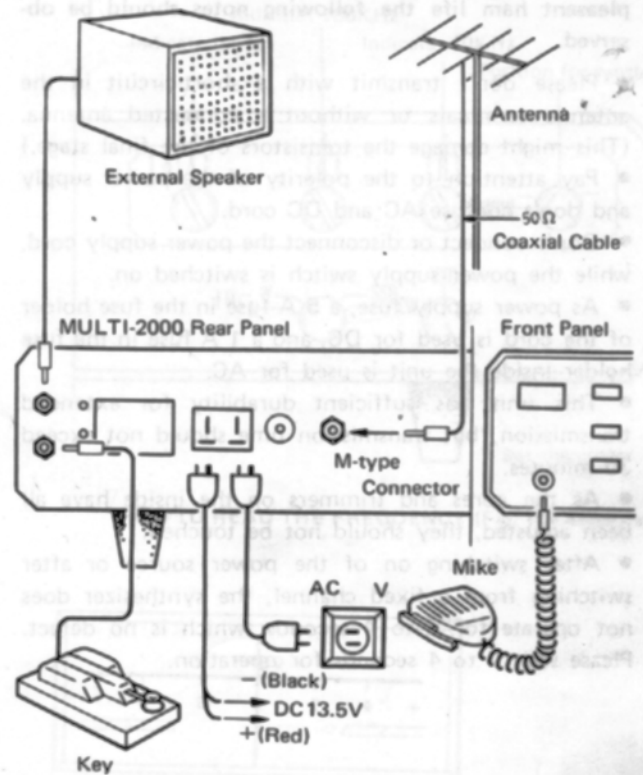

HOW TO CONNECT

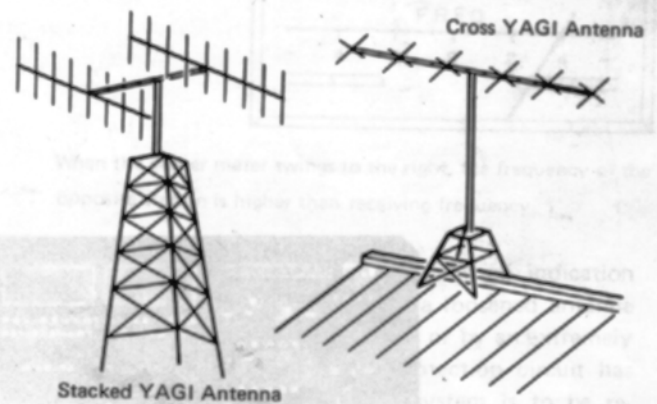

VHF ANTENNA

NOTES FOR OPERATION

HOW TO CONNECT

The MULTI-2000 has many protection circuits and has been designed for safety, but for best and most pleasant ham life the following notes should be observed.

- Please don't transmit with a short-circuit in the antenna terminals or without a connected antenna. (This might damage the transistors of the final stage.)
- Pay attention to the polarity of the power supply and don't confuse AC and DC cord.
- Don't connect or disconnect the power supply cord, while the power supply switch is switched on.
- As power supply fuse, a 5 A fuse in the fuse holder of the cord is used for DC, and a 1 A fuse in the fuse holder inside the unit is used for AC.
- This unit has sufficient durability for extended transmission, but transmission time should not exceed 30 minutes.
- As the cores and trimmers on the inside have all been adjusted, they should not be touched.
- After switching on of the power source or after switching from a fixed channel, the synthesizer does not operate for 2 to 4 seconds which is no defect. Please wait 2 to 4 seconds for operation.

- Fixed channels can be used only for FM.
- VXO and RIT are inoperable during fixed channel operation.
- As the test wave is an F_2 wave or an A_1 wave respectively, it should not be used indiscriminately by persons not having these license or more.
- When the unit is used in a car and is installed directly to the dashboard, howling occurs because of VCO oscillations, so the standard hanger of our company should be used.
- When the lock of the synthesizer does not lock, switch the power supply off and switch on again after about 4 to 5 seconds, or leave the power supply switched on and switch several times from SYNTH to FIX (1 CH) and back, which will lead to locking.



HOW TO OPERATE

When power source, mike, antenna, etc. have been connected, operation is made according to the following outline.

1. FM reception

1) When the power switch on the bottom right of the front panel is switched ON, the power supply is connected and the meter illumination and the lamps for channel indication, reception indication ("RX" green) light up.

2) The each knobs are set as follows.

SENSE	→	DX
VXO	→	Straight up (center)
RIT	→	OFF
AF GAIN	→	Turn a little to the right
SQUELCH	→	Turn full to the left
Mode selector	→	FM-W
CHANNEL	→	SYNTHE

3) The frequency is read according to the drawing and the desired channel is selected.

For listening to 1 KHz channels, the VXO knob is turned to the frequency. By turning from the center to the right, change is possible up to + 7 KHz, by turning to the left down to - 7 KHz.

4) When there is no signal on the reception channel, a humming noise is heard. When a signal is received, the noise ends, the S meter moves and the voice is heard from the speaker.

5) When the center meter swings to the left or to the right, the frequency of the reception signal has a deviation. By turning of the RIT knob setting is done to keep the pointer of the center meter always centered. This indicates correct tuning and improves the understandability. The relation between center meter and frequency is shown in the drawing.

6) For elimination of the noise at the time of no signal, the squelch knob is turned to the right and set to the point where the noise is eliminated. Care is to be taken, as a feeble signal will be eliminated together with the noise, when the knob is turned to much to the right.

7) When a local station etc. with a too strong signal is received, distortion can occur. In this case the SENSE switch is switched to LOCAL. The signal is weakened and good reception becomes possible. (for SSB)

2. FM transmission

1) When in the above described reception condition the PTT switch of the mike is pressed, transmission condition is obtained and the transmission signal lamp ("TX" orange) lights up.

2) In transmission condition the S meter becomes the output meter and indicates about [8] for an output of 10 W. When the indication of this meter is extremely low, a mismatch of the antenna system is to be taken into consideration and this

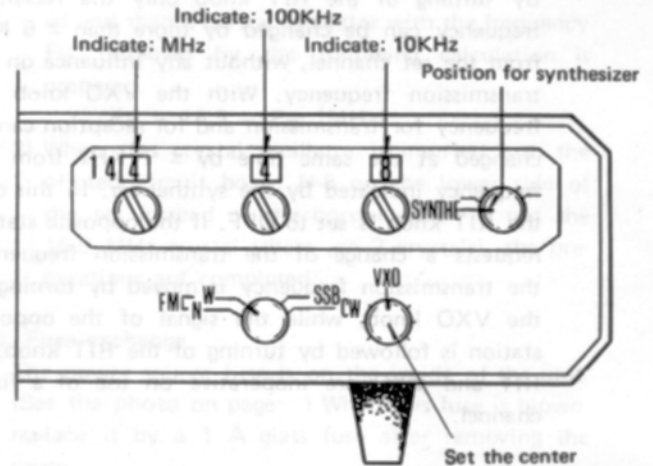

HOW TO READ THE FREQUENCY (Fig. 144.480MHz)

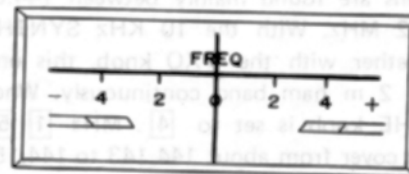

Center meter

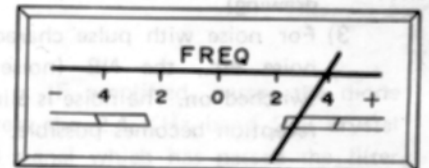

When the center meter swings to the right, the frequency of the opposite station is higher than receiving frequency.

is to be checked. When there is no indication at all, this can be caused by a loosened antenna connection, by a broken wire, or by an extremely high SWR, by which the protection circuit has acted. In this the antenna system is to be rechecked.

3) When the output meter indicates normally, talk into the mike. The best understandability is obtained with a distance of about 5 cm between mike and mouth.

4) As an output of 1 W is quite sufficient for local QSO etc., switch the POWER switch (the left switch) to L (low).

5) Set the mode selector to FM-N for operation at 20 KHz separation and transmit on narrow band. In this way the band becomes narrow and there is no interference with other stations.

6) For FM transmission the VXO knob is normally set to the center (straight up). When the VXO knob is turned to the left or the right, the transmission frequency is changed from the set channel.

HOW TO OPERATE

3. RIT and VXO

By turning of the RIT knob only the reception frequency can be changed by more than ± 5 KHz from the set channel, without any influence on the transmission frequency. With the VXO knob the frequency for transmission and for reception can be changed at the same time by ± 7 KHz from the frequency indicated by the synthesizer. In this case the RIT knob is set to OFF. If the opposite station requests a change of the transmission frequency, the transmission frequency is moved by turning of the VXO knob, while the signal of the opposite station is followed by turning of the RIT knob. RIT and VXO are inoperative on use of a fixed channel.

4. SSB reception

- 1) When in FM reception condition the mode selector is set to SSB, SSB (USB) reception condition is obtained.
- 2) SSB stations are found mainly between 144.00 and 144.32 MHz. With the 10 KHz SYNTHESIZER switch together with the VXO knob, this unit covers the 2 m ham band continuously. When the SYNTHESIZER knob is set to **4** . MHz **1** **5** , continuous cover from about 144.143 to 144.157 MHz is possible with the VXO knob (refer to drawing).
- 3) For noise with pulse characteristic like ignition noise etc., the NB (noise blanker) switch is switched on. The noise is eliminated and pleasant reception becomes possible.

5. SSB transmission

- 1) In SSB reception condition a frequency not interfering with other stations is selected and the TEST button is pressed. While the button is pressed, an A_1 wave is sent out, and an indication of about 6 to 8 of the output meter at this time is normal. If the meter indication is extremely low, this is caused by the antenna system, the same as in the case of FM, and it is to be checked.
- 2) When the meter indication is normal, transmission condition is obtained by pressing of the PTT switch of the mike. On talking into the mike, the meter pointer swings to a peak of about 6 to 8. For SSB there is no output without a voice input and the needle does not swing.
- 3) After communication has been started, the VXO knob should be touched only for a change of the transmission frequency. When the frequency of the opposite station deviates and it becomes difficult to listen, use the RIT knob to match only the reception frequency to the opposite station.
- 4) For SSB transmission the POWER (output) change-over switch and fixed channel are inoperative.

Maximum pointer to the right.

T-R Frequency = $144.15 + 0.007 = 144.157$ (MHz)

Maximum pointer to the left.

T-R Frequency = $144.15 - 0.007 = 144.143$ (MHz)

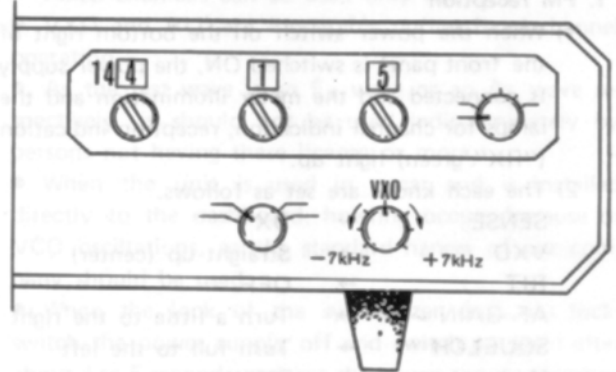

RELATION OF THE SYNTHESIZER TO THE VXO

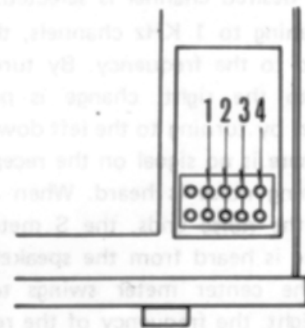

X'TAL SOCKETS FOR FIX CHANNEL

6. CW transmission and reception

CW transmission and reception operations are the same as for SSB, except that the mode selector is set to CW. The key is connected to the KEY jack on the rear and then pleasant CW operation is possible. For main CW operation No. 2 of the 9 P jack on the rear is connected to the stand-by switch and it is used together.

7. Insertion and operation method of crystals for fixed channel (only FM)

Please insert the optional crystal into the position shown in the right drawing inside the unit. 4 channels can be inserted.

These 4 channels can be separately selected by the channel selector switch and transmission and reception can be done. It is however to be observed that VXO and RIT are inoperative during fixed-channel operation.

8. TEST button

When this button is pressed, an 800 Hz F_2 wave is sent out for FM, and for SSB and CW an A_1 wave of the standard transmission frequency is sent out. This is to be used for adjustment of modulation, antenna, etc.

HOW TO OPERATE

9. Method for repeater use

Repeater is used for communication with changed transmission and reception frequency, and with this unit, repeater transmission is possible in the 144 MHz FM band.

The fixed-channel switch on the front is set to "DUPLEX" and the desired repeater reception frequency is set by the MHz, 100 KHz, 10 KHz knobs, and by turning of the VXO knob. On transmission in this condition, the radio waves are sent out at a fixed frequency difference. The difference in frequency between transmission and reception is matched to the region where it is to be used, but if it is desired to change this frequency difference, calculation is to be made according to the following formula and the crystal oscillator is to be exchanged.

- 1) First the desired frequency difference F_D (reception frequency - transmission frequency) is decided and then a crystal oscillator with the frequency F_R obtained by the following calculation is prepared.

$$F_R = 16.9 - F_D \text{ [MHz]}$$

- 2) When this crystal oscillator is inserted into the printed circuit board N-6 on the lower side of the set instead of the crystal which is not the 16.9 MHz crystal (there are 2 crystals), the preparations are completed.

10. Fuse exchange

The power source fuse is on the inside of the unit. (See the photo on page) When this fuse is blown, replace it by a 1 A glass fuse after removing the cause.

CIRCUIT DESCRIPTION

The block diagram for the MULTI-2000 is shown in Page 14. Circuit construction and operation for this unit are outlined in the following.

Receiver section

As can be seen from the block diagram, the receiver is double superheterodine for FM and single superheterodine for SSB and CW. For FM the 1st IF is 16.9 MHz and the second IF is 455 KHz, and for SSB the IF is 16.9 MHz.

The signal from the antenna enters into the RF amplifier through 3SK40 and 2SK19. The band pass filter between RF amplifier and MIXer uses a helical resonator, 3 tuning circuits in M connection, and the band content gets a level characteristic, while the outside of the band is rapidly reduced. The 1st MIXer uses 3SK40. Here it is mixed with the 127.1 to 129.1 MHz put out by the VCO (or the FIX OSC) and converted to IF16.9 MHz. The 1st IF signal of 16.9 MHz is band limited by the 16.9 MHz crystal filter, common for FM and SSB, and enters the IF amplifier through 3SK40. This amplifier is also used as noise blanker. The AGC covers the RF amplifier and this amplifier and limits the input to the mixer for large input signals (about 30 dB or more), to prevent generation of cross modulations.

The output signal of this IF stage is separated into SSB signal and FM signal, and the FM signal enters into the second mixer 3SK40, is mixed with 16.445 MHz, and is converted to 455 KHz. The 455 KHz signal is band limited in the ceramic filter LFC-20 and enters into the IF amplifier. The limiter amplifier uses IC.TA7061.

The SSB signal is IF amplified, passes the diode switch, and enters the 2.4 KHz band SSB crystal filter. The USB signal which has passed the filter is amplified in 3 stages and is converted to the AF signal in the ring demodulator consisting of 4 diodes.

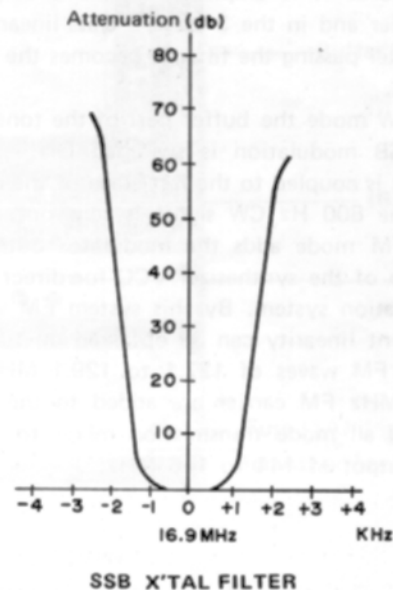

One part of the AF signal is amplified in the AFB amplifier for squelch use, is rectified, and becomes part of the squelch operation voltage. The squelch adjustment volume is also used for FM, and by use of the patented Fukuyama squelch for SSB operation, exact reception becomes possible.

The audio amplifier uses 5 W class IC, and an output of more than 2 W can be obtained at a distortion factor of 10%. A large 92 mm speaker is installed, giving a good tone quality. By use of an external 4 Ω speaker the characteristics can be increased still further.

○ Transmitter section

The modulator consisting of 3 transistor stages and diode clipper, has differential amplifier, max. oscillation width controller, and integration amplifier, the splatter filter reduces 12 dB per octave above 3 KHz, raises the degree of uniform modulation, and serves for narrowing. The clipper constant has been decided so that the deviation becomes 12 KHz for wide FM mode. For narrow operation level setting is done in the last stage, and adjustment is made for the level required for 5 KHz deviation.

For SSB operation the same method as for FM wide is used, breaking the conventional design by using a clipper circuit, preventing splatter generation through overlevel, and keeping the band width within 3 KHz.

The SSB carrier oscillator oscillates 16.8985 MHz, and for increased isolation effect the output circuit is separated for transmission and reception. The 16.9 MHz USB signal, modulated in the balanced modulator (B.M), consisting of 4 diodes, passes through filter and amplifier, and becomes the desired 144 to 146 MHz signal by mixing through 3SK40 with the all mode transmission mixer with the 127.1 to 129.1 MHz signal generated in the synthesizer. Afterwards it is amplified in the 2 stage A class amplifier and in the 3 stage B class linear amplifier, and after passing the filter it becomes the 10 W PEP output.

For CW mode the buffer part of the tone oscillator for SSB modulation is switched ON - OFF, the output is coupled to the last stage of the modulator, and the 800 Hz CW signal is sent out.

The FM mode adds the modulator output to the varicap of the synthesizer VCO for direct frequency modulation system. By this system FM waves with excellent linearity can be obtained up to 100 KHz. These FM waves of 127.1 to 129.1 MHz and the 16.9 MHz FM carrier are added to the above described all mode transmission mixer to obtain the FM output of 144 to 146 MHz.

○ Phase lock loop (P.L.L.) frequency synthesizer

A frequency synthesizer can be constructed using crystal oscillators or PLL, but for spurious characteristics and ease of adjustment the use of PLL is more effective.

This unit uses the PLL system. The genuine circuits use 3 IC's, 7 transistors, 2 FET's, 3 diodes, and plenty of semiconductors, and only for the standard signal oscillation of 10 MHz and for the station generated 13.9 MHz 2 crystals are used in the crystal oscillator.

In the following the principle will be explained following the block diagram. The standard signal oscillator uses a NAND circuit with 2 IC's, oscillates 10 MHz, and the standard 10 KHz is produced by 3, 1/10 frequency dividers.

The VCO (Voltage Control Oscillator) directly oscillates a 130 MHz band by IC, one part of the output is added to the base of the mixer 2SC1047, the station generated signal of 13.9 MHz is multiplied by 9, and enters into the emitter. The output of this high level mixer becomes an output with a difference of 2 to 4 MHz, passes 4 buffer stages, and enters into the 1/N frequency divider. Here it is divided at frequency ratios from 200 to 399, and the signal which has become 10 KHz, for phase comparison with the standard signal, becomes output proportional to the phase difference by IC in the PD (phase comparison). After passing the LPF it controls the varicap of VCO.

VXO and RIT change the frequency of the crystal for the station generated 13.9 MHz.

○ AGC, ALC circuit

For high frequency amplification AGC in SSB and CW mode the last stage of the 16.9 MHz IF is connected by capacitor to the IF amplifier for AGC and this output is rectified by diodes and used as feedback for the high frequency amplifier. This is switched ON for local and OFF for DX by the SENSE switch on the front panel. For IF the output of this IF amplifier for AGC is rectified by diodes, passes the time constant circuit, and by a 3 transistor stage DC amplifier applies the emitter voltage fluctuate to the base of the IF stage 3, and executes gain control.

The ALC rectifies by diodes the transmission output signal, it passes through the above time constant circuit and the DC amplifier and executes gain control for the IF amplifier.

INTERNAL VIEW

CHASSIS TOP

PLL Synthesizer
VCO

Fix Channel Oscillator

Relay (TR)

Stabilized Power Supply

Transistor for
Stabilizing Voltage

Power Transformer

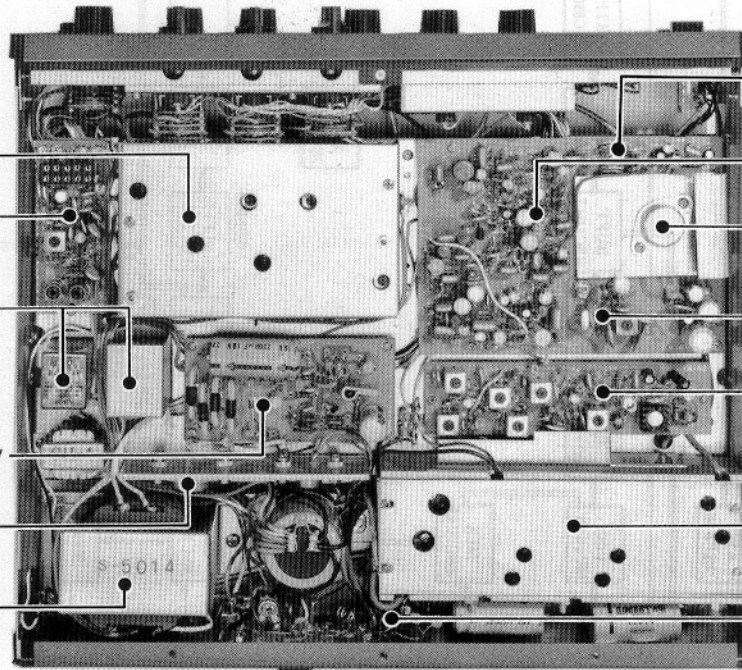

Meter Amplifier

TX-Modulator

AF Power IC

16.8985MHz
Carrier OSC (SSB)

Converter

Booster

Antenna Relay

CHASSIS BOTTOM

Receiver Section

SSB X'tal Filter

Helical Resonator

SSB IF Section

Transistor for
Voltage Control

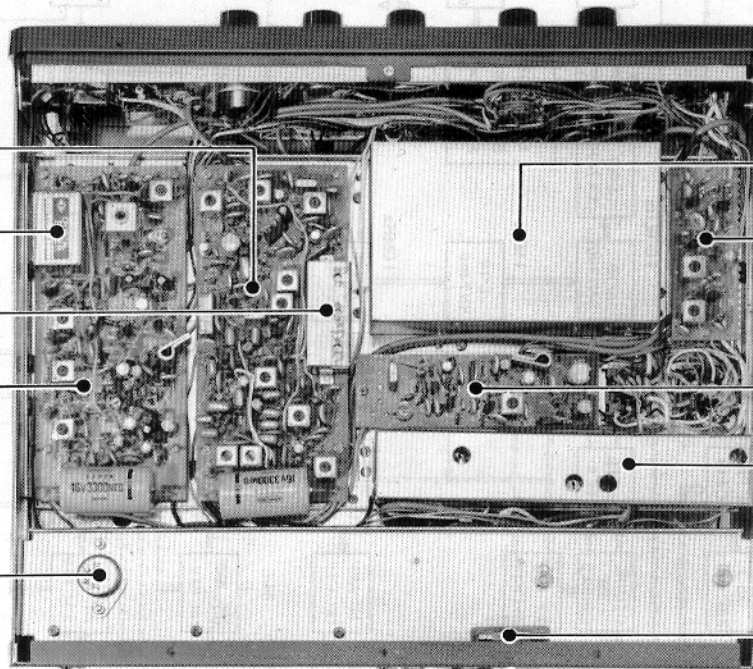

PLL
Base OSC 1/N Section

Buffer Section

16.9 OSC

Filter

Fuse (1A)
for AC power Supply



FUKUYAMA
electronics
Tokyo, Japan